

The MSCE-MS2-1-B is a waterproof and dustproof camera enclosure for Spectral Devices MSC2 series of multispectral cameras. The enclosure provides protection for cameras from harsh environments where moisture and dust are present.

FEATURES

- Compact design
- Waterproof and dustproof (IP67)
- Easy access to camera from front and back
- CNC machined aluminum components
- Black anodized finish
- Stainless steel hardware
- Large front window (Ø91 mm)
- Three versatile mounting points
- T-slot compatible mounting screw holes
- Cable entry through waterproof rubber seal

DIMENSIONS

FRONT VIEW

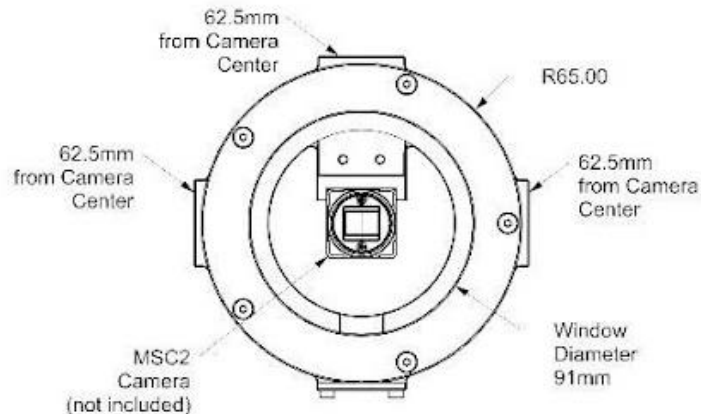

TOP VIEW

