



Specification

Multispectral Camera for Agriculture

MSC2-AGRI-1-L



MSC2-AGRI-1-L
Specifications subject to change
Revised April 24, 2024
Version 008

Table of Contents

Background Information	3
Trademarks	3
Sales and Support	3
1. Description	4
2. Key Features	4
3. Applications	4
4. Sensor and its Spectral Characteristics	6
5. Anti-X-Talk™ Technology	6
6. Specifications	7
7. Mechanical Drawings	9
8. External Connector Specifications	10
9. Package Contents	11
10. SDKs	11
11. Windows Software (optional)	12

Background Information

Trademarks

Spectral Devices Inc., MSC2, MSC2-AGRI-1-L

Sales and Support

Contact Type	Contact Information
Email	sales@spectraldevices.com support@spectraldevices.com
Knowledge Base and Downloads	www.spectraldevices.com
Main Office	Spectral Devices Inc. 800 Collip Circle, Suite 129-130 London, Ontario, Canada N6G 4X8 +1-888-988-2077

1. Description

The MSC2-AGRI-1-L multispectral linescan camera for agriculture incorporates a high performance 4MP CMOS sensor that is modified with Spectral Devices proprietary multispectral filter array technology.

This miniature multispectral snapshot camera simultaneously captures linescans at 4 distinct bands (spaced between 580 nm and 820 nm) at 3500 frames per second. There is no requirement for additional filters, filter wheels, or tunable filters.

The camera is USB3 Vision-compliant with many pre-built software options such as 2ndlook graphical camera software. Programmers can build camera applications in Windows and Linux using the included SDKs. Power is supplied through the USB3 interface.

The MSC2-AGRI-1-L is ultra-compact, ultra-light, and designed for demanding agriculture applications.

2. Key Features

- Snapshot Operation (capture spectral line images simultaneously)
- Captures 4 Bands (580, 660, 735, 820 nm)
- Anti-X-Talk™ Technology (enhances contrast and spectral performance)
- High Frame Rate (up to 3500 FPS)
- High Performance (4MP Global Shutter CMOS Sensor)
- USB3 Vision & GenICam Compliant
- Ultra compact (28 mm x 28 mm x 47 mm)
- Ultralight (< 55 g)
- Low Power Requirement (< 4W from USB cable)
- Multiple M2 and M4 screw mounting Points
- SDK for Windows and Linux included

3. Applications

The camera is suitable for remote sensing in agriculture. The 580 nm band is known as chlorophyll reflectance peak in the visible light spectrum. The Red, Red Edge and NIR bands can be used to assess plant health, detect diseases early, and optimize crop yields using such metrics as Normalized Difference Vegetation Index (NDVI) and Normalized Difference Red Edge Index (NDRE). Table 3.1. lists example metrics that can be used for multispectral analysis using MSC2-AGRI-1-L.

Combined with Spectral Devices SBC-1 miniature vision computer, the MSC2-AGRI-1-L offers an easy-to-use lightweight and modular imaging solution for UAV users.

Table 3.1. Example metrics for multispectral analysis using MSC2-AGRI-1-L camera

METRIC	FULL NAME	BANDS	EQUATION	INTERPRETATION
NDRE	Normalized Difference Red Edge Index	NIR, Red Edge	$NDRE = (NIR - RedEdge) / (NIR + RedEdge)$	<p>Range from -1 to +1. A higher NDRE indicates greater plant health, reflecting denser and greener vegetation. This is crucial for assessing crop vitality and identifying areas needing attention.</p> <p>This metric performs better in crops at late stages of growth.</p>
EVI	Enhanced Vegetation Index	NIR, Red, Blue	$EVI = G * ((NIR - Red) / (NIR + C_1 * Red - C_2 * Blue + L))$, where C_1 and C_2 are coefficients for atmospheric resistance, L - value to adjust for canopy background	<p>Range from -1 to +1. Higher EVI values generally indicate healthier and more vigorous vegetation, while negative values may indicate non-vegetated surfaces or water bodies.</p> <p>This metric corrects for atmospheric conditions and canopy background noise. Compared to previously listed metrics it is more sensitive in areas with dense vegetation and to canopy structural variations such as leaf size and canopy type.</p>
MSAVI2	Modified Soil Adjusted Vegetation Index	NIR, Red	$MSAVI2 = (2 * NIR + 1 - \sqrt{(2 * NIR + 1)^2 - 8 * (NIR - Red)}) / 8$	<p>Ranges from -1 to +1. Higher MSAVI values generally indicate healthier and more vigorous vegetation, while negative values may indicate non-vegetated surfaces or soil.</p> <p>Used when a lot of soil is present, in early crop development stages.</p>

4. Sensor and its Spectral Characteristics

The MSC2-AGRI-1-L camera has 4 distinct bands centered at 580, 660, 735, 820 nm (FWHM ~25 nm). The sensor of the camera is covered with a multispectral filter array providing each sensor element (pixel) its own spectral response (Fig.4.1a). In case of the line camera filters are arranged in rows. The spectral response of the MSC2-AGRI-1-L camera filters is displayed in Fig.4.1b.

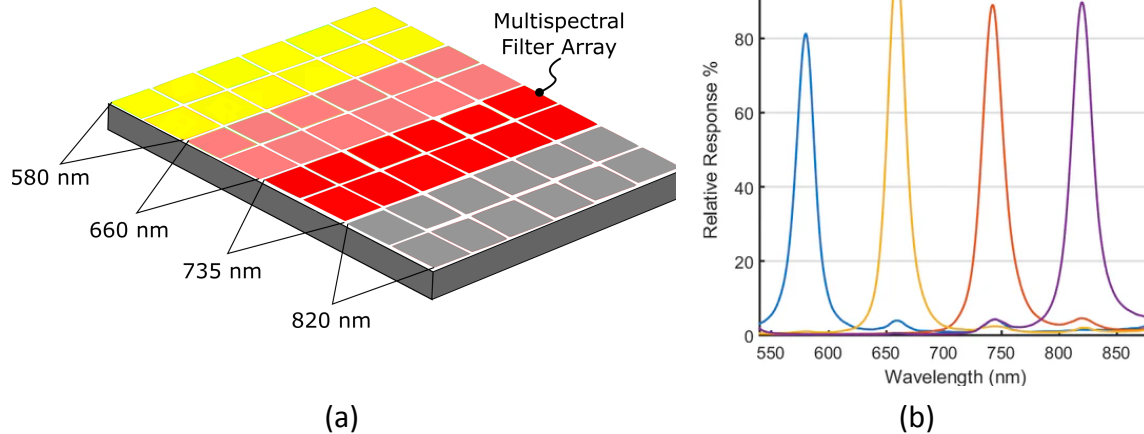

Figure 4.1. (a) Example of MSC2-AGRI-1-L multispectral filter array structure (note: band arrangement can vary between cameras) (b) Spectral response of the MSC2-AGRI-1-L camera.

5. Anti-X-Talk™ Technology

Anti-X-Talk™ technology is a unique Spectral Devices Inc. on-chip technology working at the filter level and preventing light leakage between individual filters. Without Anti-X-Talk™ technology, stray light between spectral channels is significant, often exceeding the light leakage due to spectral overlap between adjacent filters. As a result images suffer from low contrast and spectral ambiguity.

Spectral Devices invented Anti-X-Talk™ technology to overcome these problems. It works by blocking stray light between adjacent filters, making the pixel response more predictable and directly related to the actual spectral response of the overlying pixelated filter. The result is multispectral images with better spectral discrimination and higher contrast.

Furthermore, high quality image data from the MSC2-AGRI-1-L can be used as is without the need for proprietary post-processing algorithms and the camera can be used with a wide range of lens types even at large apertures (e.g. f/2).

6. Specifications

Lens Mount	C-mount
Sensor Type	CMOS
Sensor Model	AMS CMV4000
Sensor Format	1-inch
Number of Spectral Channels	4
Image Pixels Per Spectral Channel	2048x8
Effective Pixel Size (H x V)	5.5 μm x 5.5 μm
Capture Method	Line
Spectral Channels	580, 660, 735, 820 nm
Spectral Bandwidth (FWHM)	~25 nm
On-chip Spectral Enhancement	Anti-X-Talk™ Technology
Shutter Type	Global
Sync System	External trigger (Hardware, Software) / Free run
Maximum Frame Rate (at Full Frame)	8bits output 3500 fps 10bits output 1900 fps 12bits output 1600 fps
ADC bit width	10bits / 12bits
Video Format	8bits / 10bits / 12bits output
Noise Level	8bits output: <3 digits (Gain 0 dB) 10bits output: <12 digits (Gain 0 dB) 12bits output: <48 digits (Gain 0 dB)
Sensitivity (*)	210 Lux
Exposure time	22 μs to 16.77 seconds (Default: 11,116.0 μs)
Digital Gain	0 to 13.9 dB (Default: 0 dB)
Black Level	8bits output: 0 to 15 digits 10bits output: 0 to 63 digits 12bits output: 0 to 255 digits
Binning	Turned off for multispectral readout
Decimation	Turned off for multispectral readout
HDR	Turned off for multispectral readout
Image Flip	Horizontal / Vertical / Horizontal and Vertical / Off
Defective Pixel Correction	Turned off for multispectral readout
Auto Exposure	Supported
Auto Gain	Supported
Operational Mode	Edge preset Trigger / Pulse width Trigger / Start Stop Trigger / Free run
User Setting Storage	Supported
Communication	Through USB3.0 bus
Interface	USB3.0 Super speed (USB3.0 micro B)
Protocol	USB3 Vision® 1.0.1, GenICam Standard Version (SFNC 2.2, PFNC 2.0) compliant

Input / Output	Three GPIOs, One Camera Hardware Reset
Power Input Voltage	+5V (typ.) (This conforms to USB standard)
Power Consumption	Less than 4.0 W
Case Construction	Anodized Aluminum
Mounting Holes	4 x M4 (bottom), 2 x M4 (top), 3 x M2 (4 sides)
Overall Size	28 mm x 28 mm x 47 mm (W x H x L)
Weight	< 55 g
Operational Temperature / Humidity	Minimum Environmental Temperature: 0 deg. C, Environmental Humidity: 0 to 85 %RH (No condensation) Maximum Camera housing temperature (top plate) shall not exceed 55 deg. C
Storage Temperature / Humidity	Environmental Temperature: -30 to +65 deg. C Environmental Humidity: 0 to 85 %RH (No condensation)
Vibration	20 Hz to 200 Hz to 20 Hz (5 min. / cycle), acceleration 10 G, XYZ 3 directions 30 min. each
Shock Acceleration	38 G, half amplitude 6 ms, XYZ 3 directions 3 times each
Standard Compliance	EMS: EN61000-6-2, EMI: EN55011
RoHS	RoHS Compliant

(*) The sensitivity was measured as the luminance when white level achieved 100 % using the settings and conditions below.

Camera Setting		Environment	
Parameter	Setting	Parameter	Setting
Gain Up	0 dB	Light Source	Light Box (White)
AGC	Off	Color temperature	5,100K
White Balance	Optimum	Lens	
Electrical Shutter	1/30 seconds	F on Lens	F5.6
Black Level	Optimum	Target Luminance	IM-600 (Topcon)
Gamma	Factory Setting		

(**) The multiple ROI regions cannot be set on the same horizontal line.

7. Mechanical Drawings

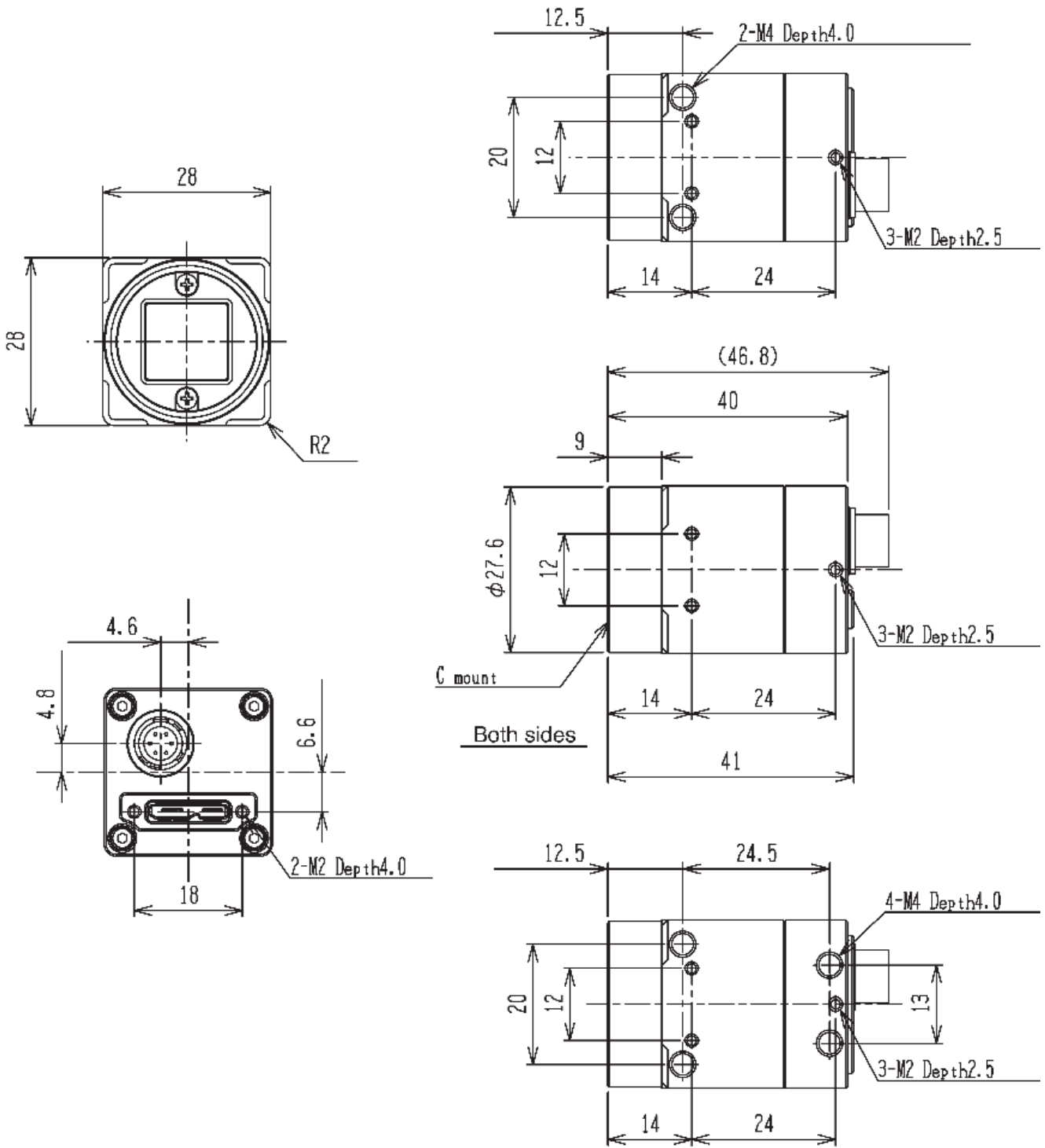

8. External Connector Specifications

The camera has 2 external connectors - USB3.0 micro B type and I/O (HR10A-7R-6PG (Hirose) or equivalent) (Fig.8.1a). The USB3.0 provides the camera with input voltage of +5V, while Hirose is used for signal transfer and can be configured for input or output and programmed for trigger or strobe functions. The hirose connector pin assignment is laid out in Fig.8.1b.

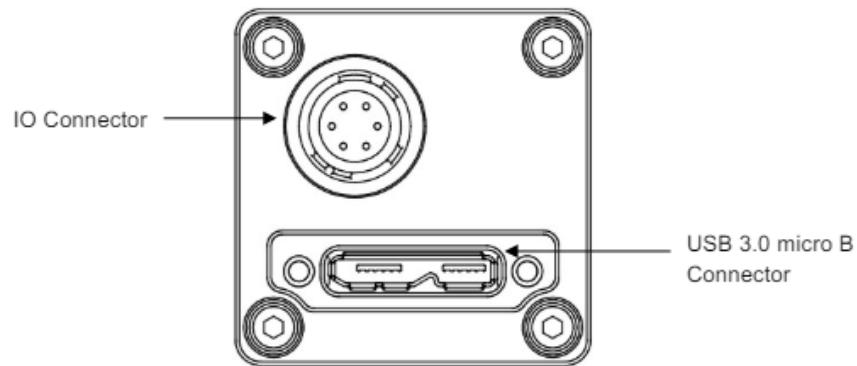

(a)

Pin No.	Signal Name	IN/OUT
1	GPIO_GND	-
2	GPIO2	IN/OUT
3	GPIO1	IN/OUT
4	GPIO0	IN/OUT
5	CAM_RESET	IN
6	N.C.	-

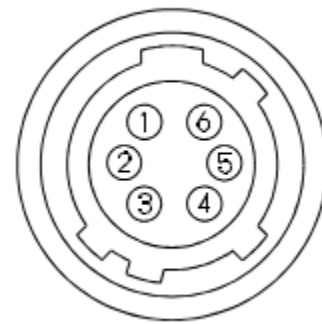

(b)

Figure 8.1. (a) MSC2-AGRI-1-A external connectors - USB3.0 and hirose (b) MSC2-AGRI-1-A hirose connector pin assignment

Additional information on the pin assignment is provided below.

Pin No.	Signal Name	Function	IN/OUT	Voltage		Current	Reference	
				Low Voltage	High Voltage			
1	IO_GND	GND	-			-	-	
2	GPIO2	General Purpose Input Output	IN/OUT	IN	Less than +1.00 V	+3.00 to +24 V	4 µA (typ.) (*4)	2
				OUT	0 to +2.20V (*1)	+3.00 to +24 V (*2)	15 mA (Max.) (*3)	3,4
3	GPIO1	General Purpose Input Output	IN/OUT	IN	Less than +1.00 V	+3.00 to +24 V	4 µA (typ.) (*4)	2
				OUT	0 to +2.20 V (*1)	+3.00 to +24 V (*2)	15 mA (Max.) (*3)	3,4
4	GPIO0	General Purpose Input Output	IN/OUT	IN	Less than +1.00 V	+3.00 to +24 V	4 µA (typ.) (*4)	2
				OUT	0 to +2.20 V (*1)	+3.00 to +24 V (*2)	15 mA (Max.) (*3)	3,4
5	CAM_RESET	Camera Hardware Reset	IN	IN	Less than +0.80 V	+3.00 to +24 V	4 µA (typ.)(*4)	1
6	N.C.	NC	-			-	-	

(*1) The case that output low voltage on 15mA load. The output voltage could be higher voltage due to the generate voltage by the internal resistor when the power consumption is large with low voltage output. Please evaluate carefully with the actual system.

(*2) The maximum voltage can be applied to connecting IO port as output IO port when external circuits connecting to IO port. This is equivalent to VCCext on Reference 4.

(*3) When external IO port is connected, control the current less than 15mA on IO port. Please do not apply more than 15 mA to connecting IO port as output IO port when external circuits connecting to IO port.

(*4) The typical current value when high voltage input into Input port.

9. Package Contents

Each camera is supplied with a USB3.0 Vision cable and tripod adapter in a waterproof equipment case for transport and storage.

10. SDKs

Included with the MSC2-AGRI-1-L is an industrial-grade SDK for camera control and image capture. The SDK is compatible with a variety of Windows, Linux and MacOS operating systems. It includes drivers, libraries, documentation, and samples. Environments such as Python and OpenCV are also supported.

Operating System	Development Environments	SDK Includes
Windows 11 (64bit) Windows 10 (32bit / 64bit) Windows 8.1 (32bit / 64bit)	Visual Studio 2005 Visual Studio 2008 Visual Studio 2010 Visual Studio 2012 Visual Studio 2013 Visual Studio 2015 Visual Studio 2017 Visual Studio 2019 Visual Studio 2022 MinGW (Minimalist GNU for Windows)	Windows driver Windows SDK StApi (Visual C++, .net Framework 2.0, C) StGenTL module Viewing Software (StViewer) Sample Programs (Visual C++, Visual C#, Visual Basic, C) DirectShow Filter Documentation

	embarcadero Free C++ Compiler Python 3.7.x Python 3.8.x Python 3.9.x Python 3.10.x	
MacOS 13 Ventura MacOS 12 Monterey MacOS 11 BigSur	Python 3.7.x Python 3.8.x Python 3.9.x Python 3.10.x	StApi (C++) StGenTL module Viewing Software (StViewer) Sample Programs Documentation
Linux 64bit x64 Linux 64bit ARM Linux 32bit ARM	Python 3.7.x Python 3.8.x Python 3.9.x Python 3.10.x	StApi (C++, C) StGenTL module Viewing Software (StViewer) Sample Programs (C++, C) Documentation

11. Windows Software (optional)

2ndLook is an optional image acquisition software package offering a complete solution to the customers looking for a user-friendly way to connect and acquire images without any development experience necessary. The software enables real-time synchronized video and image recording from GenICam-compliant USB3 Vision, GigE Vision, and DirectShow cameras (Fig. 10.1).

2ndLook supports popular file formats, such as AVI, TIFF, PNG, JPEG and allows recording from multiple cameras to different file formats concurrently.

Multispectral imaging conversion filters for Spectral Devices Inc. cameras are built in in the software (Fig. 10.2). This allows users to view montages of spectral images in real-time (Fig. 10.3). The built-in debayering algorithm displays color images from the raw RGB multispectral images.

It is an easy to use interface with interactive help and user guides. Demo version provides all features, except save to disk function.



Figure 10.1. Real-time display of raw multispectral images.

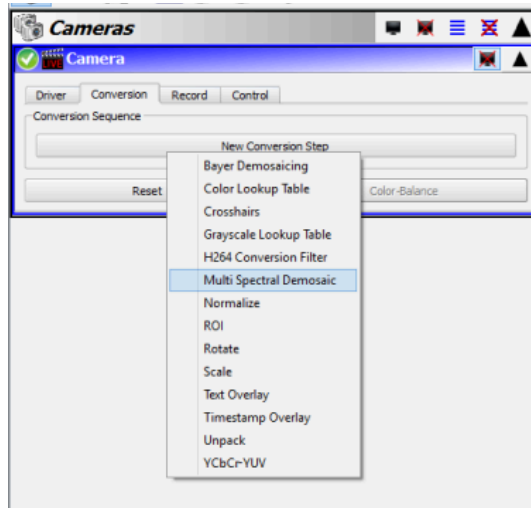

Figure 10.2. Multispectral conversion filters



Figure 10.3. Real-time display of multispectral images in montage format. Example here collected with a 4-band multispectral camera for agriculture.