

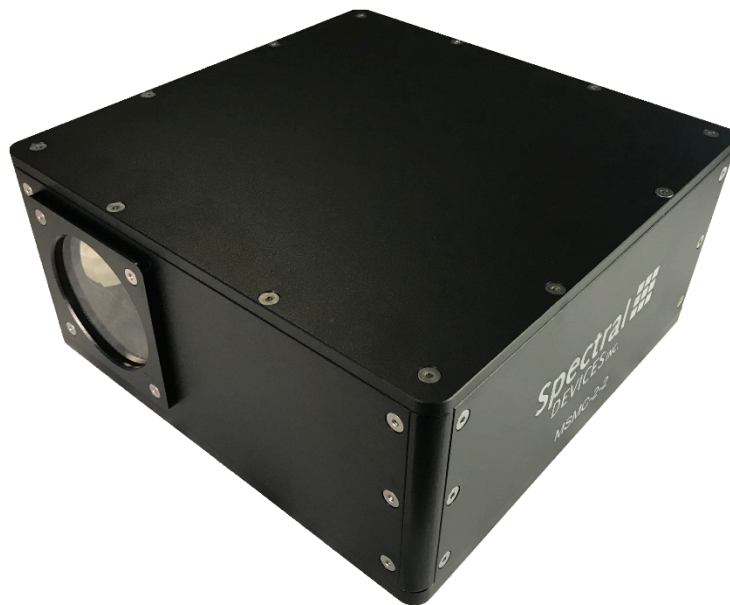

Specification

Multispectral Multicamera Imaging System

MSMC-2-2-C42-UN-1-A



MSMC-2-2-C42-UN-1-A
Specifications subject to change

Revised April 29, 2022

Table of Contents

Background Information	2
Trademarks	3
Sales and Support	3
1. Description	4
2. Specifications	4
3. Camera Sensors	5
Anti-X-Talk™ Technology	5
4. Drawings	7
Exterior	7
Interior	8
5. Camera and Sensor Geometry	9
5. SDKs	9
6. Windows Software	10

Background Information

Trademarks

Spectral Devices Inc., MSC2, MS2-C42-1-A, MS-2-UN-1-A, MSMC-2-2-C42-UN-1-A

Sales and Support

Contact Type	Contact Information
Email	sales@spectraldevices.com support@spectraldevices.com
Knowledge Base and Downloads	www.spectraldevices.com
Main Office	Spectral Devices Inc. 800 Collip Circle, Suite 129-130 London, Ontario, Canada N6G 4X8 +1-888-988-2077

1. Description

The MSMC-2-2 is a multispectral multicamera imaging system incorporating two multispectral cameras into a single housing. The MSMC-2-2-C42-M42-1-A version includes a color camera (MC2-C42-1-A) and UV-NIR (MC2-UN-1-A) camera with spectral bands in ultraviolet and near-infrared range.

Each camera has its own lens and views the scene (object) through a plate beam splitter. The beam splitter enables each camera to observe the same scene without parallax effects.

Both cameras are USB3 Vision and GenICam compliant offering many options for image acquisition software, SDKs and OS platforms. The system is supplied with Windows-based 2ndLook software providing easy setup and simultaneous recording of images from both cameras.

Both cameras come hardwired in a master/follower arrangement allowing one camera to trigger the other. This ensures simultaneous image capture on both cameras. Each camera can have independent exposure settings to accommodate differences in sensitivity of each camera.

The cameras and beam splitter are mounted on 3-degree of freedom (DOF) stages enabling alignment of the beam splitter and each camera to the scene (object) using an Allen key after removal of the lid. One camera has adjustments for roll, yaw and x. The second camera and beam splitter have adjustments for roll, pitch, and z.

Power is provided to each camera through the USB3 interface. The housing is constructed from thick aluminum for stability and hard anodized for durability. The housing is dustproof.

2. Specifications

Dimensions (H x W x D) – not including feet	116 mm x 250 mm x 250 mm
Foot adjustment	20-40 mm
Aperture	77 mm screw on protective glass filter. User replaceable.
Camera 1	MSC2-C42-1-A (4MP color camera)
Camera 2	MSC2-UN-1-A (4MP camera, 2048x512px per band)
Camera 1 spectral bands	450, 550, 650 nm
Camera 2 spectral bands	400, 800 nm
Camera 1 mount	3 DOF – roll, yaw, y
Camera 2 mount	3 DOF – roll, pitch, z
Beam splitter mount	3 DOF – roll, pitch, z
Beam splitter options	Glass plate 50:50 (R/T). Other options available.
Distance between camera C-mount and Beam splitter	Adjustable from 40 mm to 80 mm
Lens options	1-inch fixed focal length, manual focus, manual iris, locking screws. Many options available.

Rear connector	2 x USB 3 Type-B (female)
Tripod mounting	4 x ¼-20 and 4 x M6 threaded holes on bottom near center
Construction	CNC 6061 Aluminum, Brass and Stainless-Steel hardware
Surface finish	Hard anodized black

3. Camera Sensors

Quantum efficiency of the MSC2-C42-1-A shown in Fig 3.1a. The sensor of the MSC2-UN-1-A camera is covered with a multispectral filter array providing each sensor element (pixel) its own spectral response (Fig.3.1b). This results in perfectly co-registered images between the spectral bands.

Anti-X-Talk™ Technology

The MSC2-UN-1-A camera sensor is made with Anti-X-Talk™ technology, which is an unique Spectral Devices Inc. on-chip technology working at the filter level and preventing light leakage between individual filters. Without Anti-X-Talk™ technology, stray light between spectral channels is significant, often exceeding the light leakage due to spectral overlap between adjacent filters. As a result images suffer from low contrast and spectral ambiguity.

Spectral Devices invented Anti-X-Talk™ technology to overcome these problems. It works by blocking stray light between adjacent filters, making the pixel response more predictable and directly related to the actual spectral response of the overlying pixelated filter. The result is multispectral images with better spectral discrimination and higher contrast.

Furthermore, high quality image data from the MSC2-UN-1-A can be used as is without the need for proprietary post-processing algorithms and the camera can be used with a wide range of lens types even at large apertures (e.g. f/2).

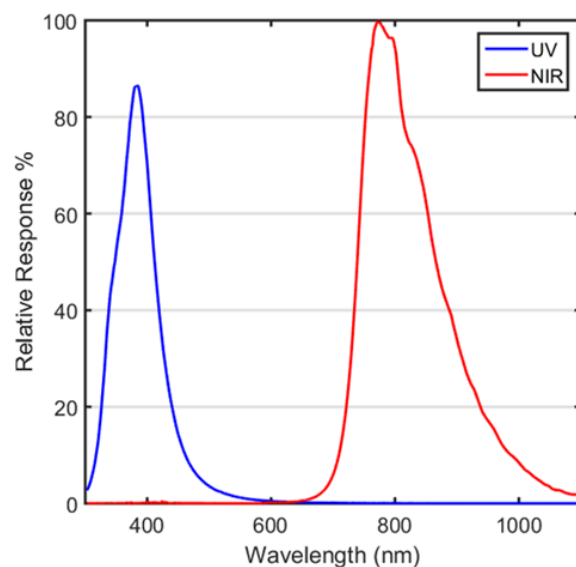
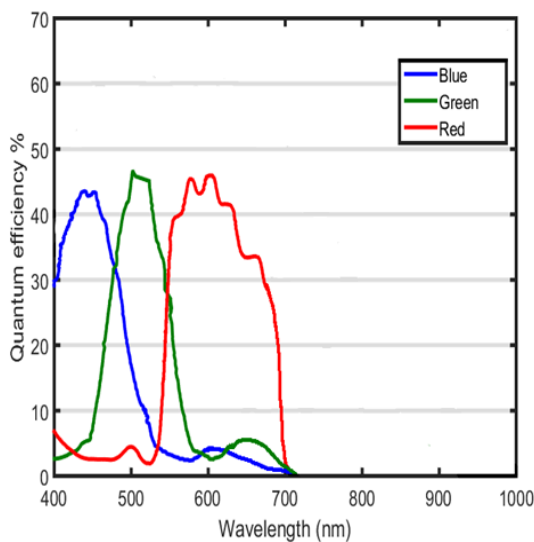

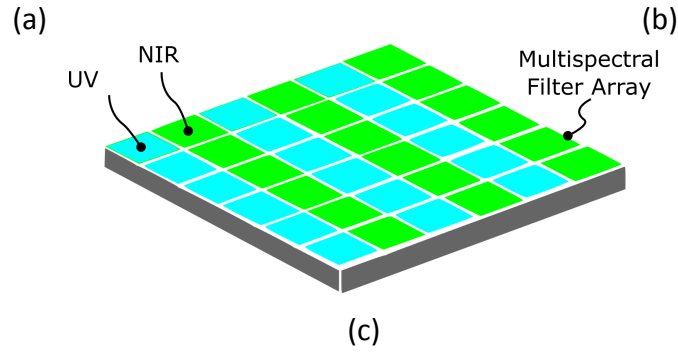
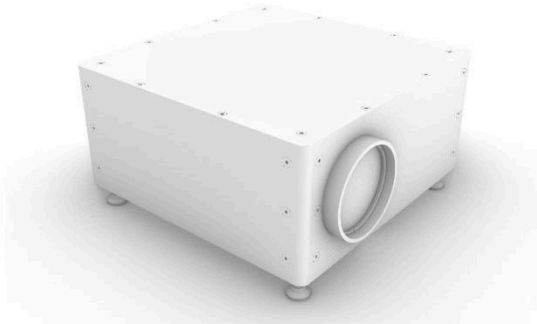

Figure 3.1 (a) Quantum efficiency of the MSC2-C42-1-A sensor, (b) Spectral response of MSC2-UN-1-A sensor, (c) Example of MSC2-UN-1-A multispectral filter array structure (note: band arrangement can vary between cameras).

4. Drawings

Exterior

RENDERED FRONT VIEW



RENDERED BACK VIEW



TOP VIEW

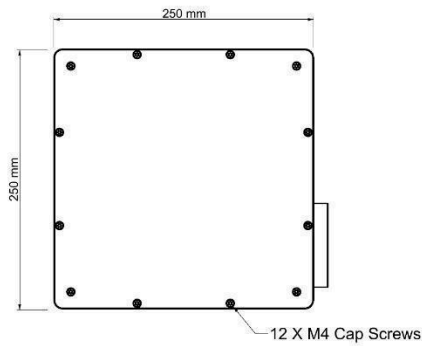

BOTTOM VIEW

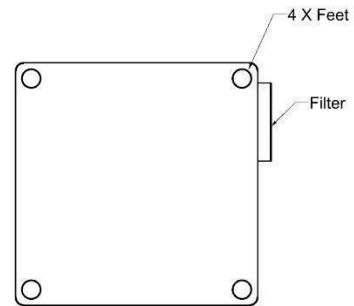

FRONT VIEW

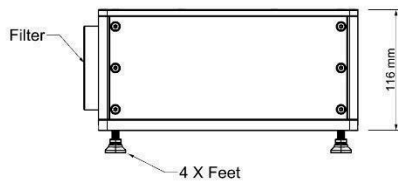

BACK VIEW

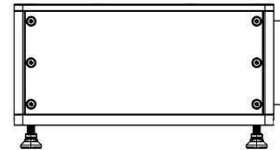

LEFT VIEW

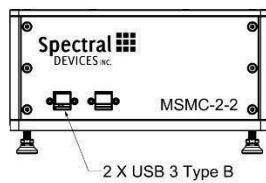

RIGHT VIEW

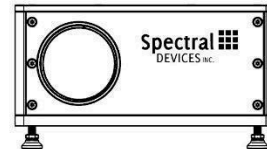

Interior

RENDERED FRONT VIEW

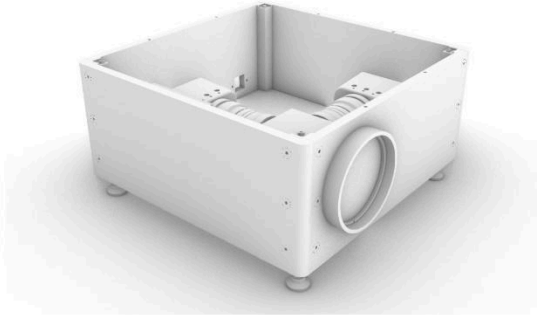

RENDERED BACK VIEW

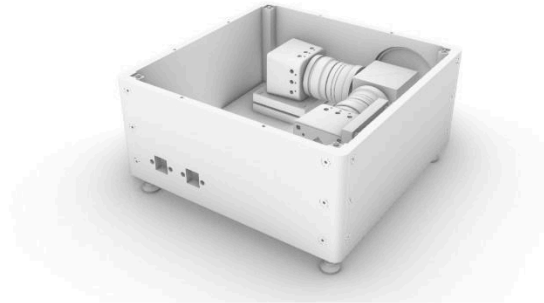

TOP VIEW

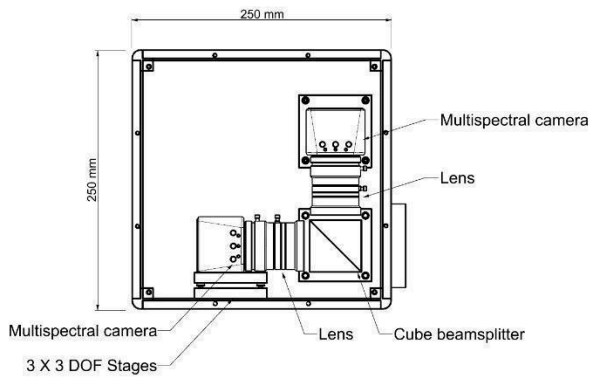

BOTTOM VIEW

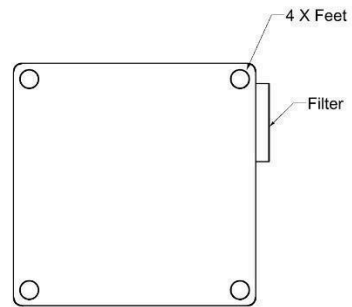

FRONT VIEW

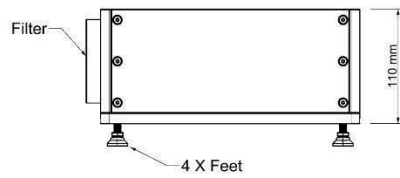

BACK VIEW

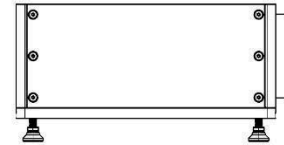

LEFT VIEW

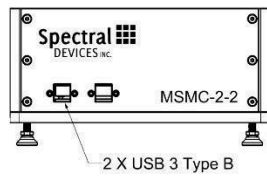

RIGHT VIEW

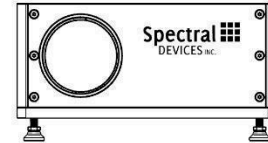

5. Camera and Sensor Geometry

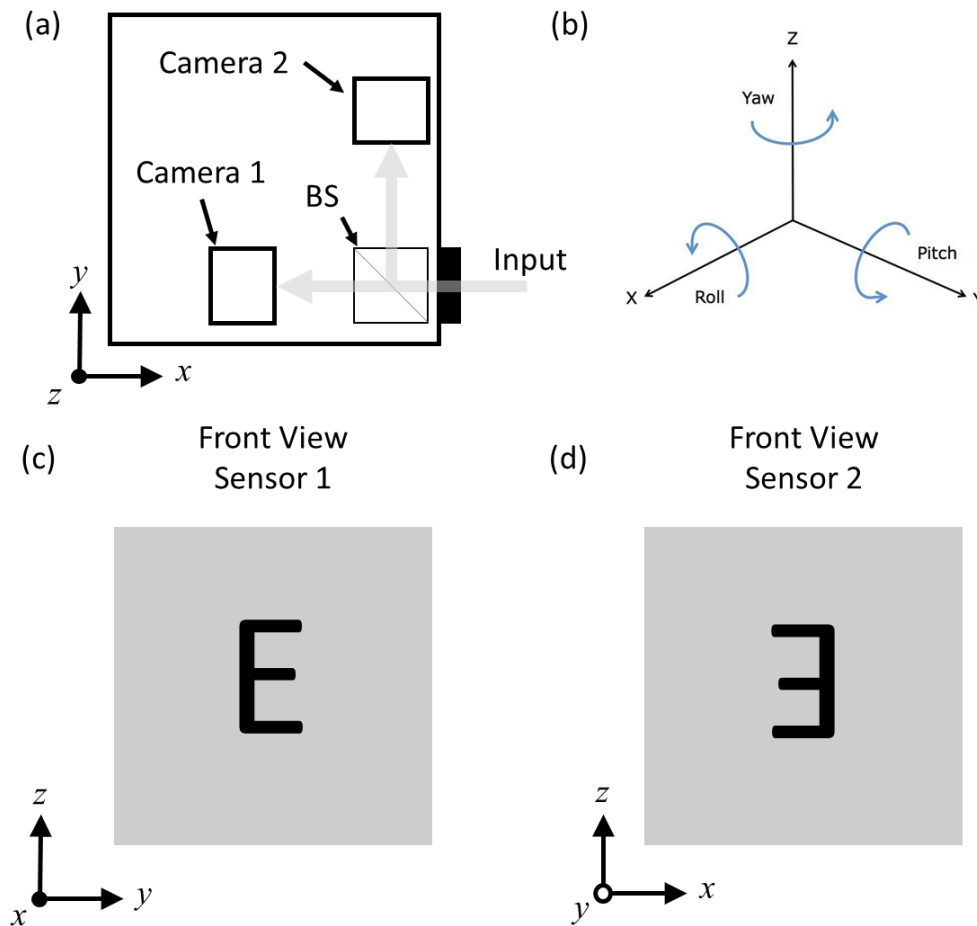

- (a) General layout of cameras within the MSMC-2-2 showing orientation of cameras with respect to the beam splitter (BS) and the MSMC-2-2 coordinate system.
- (b) Definition of yaw, pitch and roll with respect to the MSMC-2-2 coordinate system.
- (c) Front view of sensor inside camera 1 and its relationship to the coordinate system of the MSMC-2-2. The letter 'E' indicates the orientation of the image of an object.
- (d) Front view of sensor inside camera 2 and its relationship to the coordinate system of the MSMC-2-2. The orientation of the letter 'E' indicates that the image of the object is a mirror image of the image obtained with camera 1. The image is flipped horizontally in software during operation.

5. SDKs

Included with the MSMC-2-2 is an industrial-grade SDK for camera control and image capture. The SDK is compatible with a variety of Windows, Linux and MacOS operating systems.

It includes drivers, libraries, documentation, and samples. Environments such as Python and OpenCV are also supported.

Operating System	Development Environments	SDK Includes
Windows 11 (64bit) Windows 10 (32bit / 64bit) Windows 8.1 (32bit / 64bit)	Visual Studio 2005 Visual Studio 2008 Visual Studio 2010 Visual Studio 2012 Visual Studio 2013 Visual Studio 2015 Visual Studio 2017 Visual Studio 2019 Visual Studio 2022 MinGW (Minimalist GNU for Windows) embarcadero Free C++ Compiler Python 3.7.x Python 3.8.x Python 3.9.x Python 3.10.x	Windows driver Windows SDK StApi (Visual C++, .net Framework 2.0, C) StGenTL module Viewing Software (StViewer) Sample Programs (Visual C++, Visual C#, Visual Basic, C) DirectShow Filter Documentation
MacOS 13 Ventura MacOS 12 Monterey MacOS 11 BigSur	Python 3.7.x Python 3.8.x Python 3.9.x Python 3.10.x	StApi (C++) StGenTL module Viewing Software (StViewer) Sample Programs Documentation
Linux 64bit x64 Linux 64bit ARM Linux 32bit ARM	Python 3.7.x Python 3.8.x Python 3.9.x Python 3.10.x	StApi (C++, C) StGenTL module Viewing Software (StViewer) Sample Programs (C++, C) Documentation

6. Windows Software

2ndLook software is included with each system purchase. 2ndLook is an image acquisition software package offering a complete solution to the customers looking for a user-friendly way to connect and acquire images without any development experience necessary. 2ndLook provides real-time synchronized video recording from multiple cameras (GenICam-compliant USB3 Vision, GigE Vision, and DirectShow cameras) to popular file formats (AVI, TIFF, PNG, JPEG) (Fig. 6.1). It has an easy to use interface with interactive help and user guides.



Figure 6.1. Real-time display of raw multispectral images.