

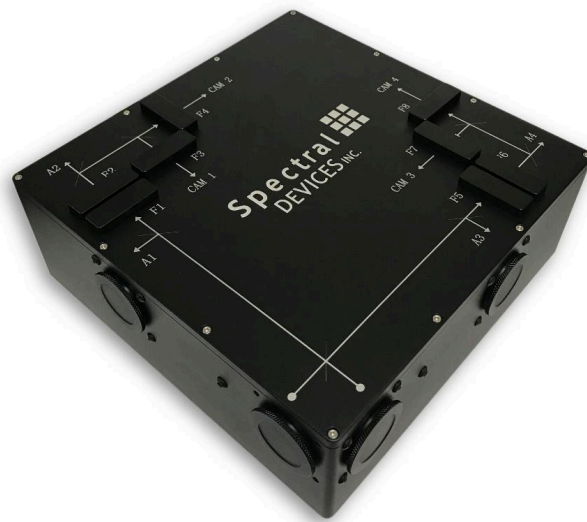

# Specification

## Multispectral Multicamera Microscopy System

### MSMC-1-4



MSMC-1-4

Revised April 25, 2023

# Table of Contents

1. Description.....	3
MSMC-1-4-23-1-A.....	3
MSMC-1-4-42-1-A.....	3
MSMC-1-4-51-1-A.....	3
MSMC-1-4-200-1-A.....	4
2. System photos.....	4
3. Model-Specific Specifications.....	5
5. Drawings.....	6
System Layout.....	6
Front.....	7
Back.....	7
6. SDKs.....	8
7. Windows Software.....	8

# 1. Description

Spectral Devices MSMC multispectral multicamera systems are designed for demanding microscopy applications. The system has 4 resolution configurations - MSMC-1-4-23-1-A, MSMC-1-4-42-1-A, MSMC-1-4-51-1-A, MSMC-1-4-200-1-A, corresponding to 2.3 MP, 4.2 MP, 5.1 MP and 20.0 MP, respectively.

Each system comes with 4 CMOS cameras mounted within a single box that are optically aligned to accept light from a single C-mount entrance port. The system splits light from a single C-mount entrance port into 4 channels for simultaneous imaging. Eight removable standard 1-inch filter holders are inserted at locations within the 4 optical paths.

User can use any camera as an internal trigger source or connect all four cameras to an external trigger source. All cameras can be synchronized with external devices using the sync signal. The systems are expandable with up to 4 external C-mount cameras or detectors

All cameras have a global shutter to provide accurate high-speed images of moving objects in the field of view. USB3 Vision and GenICam-compliance makes system setup and use easy.

The enclosure is CNC-machined from aluminum for strength and hard anodized for durability. 2ndLook for Windows is included with each system to simplify system setup and use. Advanced users can create custom programs in Windows, Linux, RaspberryPI, and MacOS using the supplied SDK.

## **MSMC-1-4-23-1-A**

Includes 4 Sony IMX249 2.3 MP sensors suitable for fluorescence imaging. The IMX249 sensors have very low noise and can detect fluorescence at short exposure times. The system is capable of fluorescence video microscopy of stained tissue at up to 20 FPS. Maximum frame rate is 41 FPS at full frame. The sensors can be exposed for extended times to capture very weak fluorescence signals.

## **MSMC-1-4-42-1-A**

The 4.2MP multispectral microscopy system includes four CMV4000 image sensors. The CMV4000 has a large pixel size and very fast read out resulting in a combination of high frame rate and excellent sensitivity. The system is capable of simultaneously capturing 4 images at 89 FPS at full frame. Several thousand frames per second are achievable when using a small region of interest.

## **MSMC-1-4-51-1-A**

The 5.1MP multispectral microscopy system includes four Sony IMX250 image sensors, which offer low noise and high dynamic range. Maximum frame rate is 75 FPS at full frame.

## MSMC-1-4-200-1-A

The 20MP multispectral microscopy system includes four Sony IMX183 image sensors, which offer the highest sensor resolution in the MSMC-1-4 series. Maximum frame rate is 18 FPS at full frame.

## 2. System photos

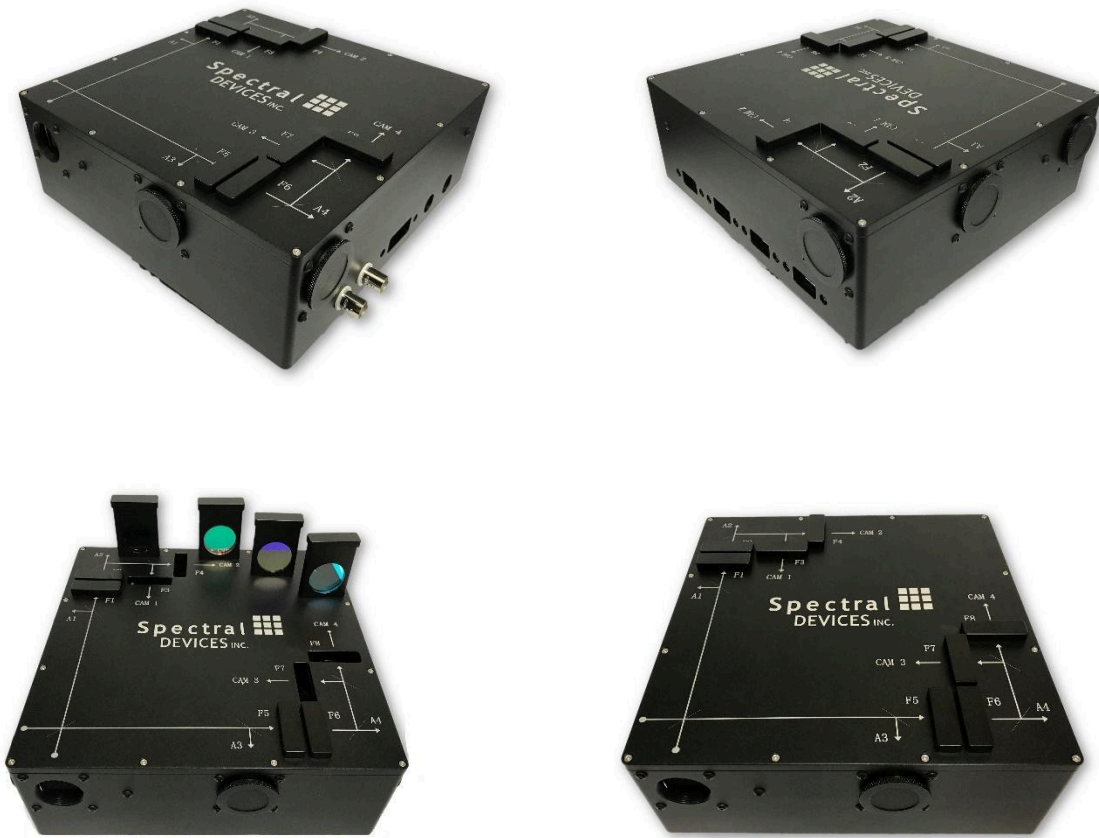

Figure 2.1. Images of the MSMC-1-4 system.

### 3. Model-Specific Specifications

	MSMC-1-4-23-1-A	MSMC-1-5-42-1-A	MSMC-1-5-51-1-A	MSMC-1-5-200-1-A
Sensor Model	IMX249	CMV4000	IMX250	IMX183
Sensor Manufacturer	Sony	AMS	Sony	Sony
Sensor Size	1/1.2-inch	1-inch	2/3-inch	1-inch
Pixel Resolution	1920 x 1200	2048 x 2048	2448 x 2048	5472 x 3648
Pixel Size (µm)	5.86 x 5.86	5.5 x 5.5	3.45 x 3.45	2.4 x 2.4
Max. Frame Rate	41 FPS	89 FPS	75 FPS	18 FPS
Shutter Type	Global	Global	Global	Rolling
Illumination	Front-illuminated	Front-illuminated	Front-illuminated	High sensitivity back-illuminated
Options	Mono/Color	Mono/Color	Mono/Color	Mono/Color

### 4. General Specifications

Aperture	Two C-Mount ports (left and right) available. User must choose one entrance port at time of order.
Camera options	See Section 2 above
Filter holders	8 total. 4 per arm. Retaining rings included. Rotation adjustment slot for polarizers.
Compatible filter sizes	25 mm diameter, 25.4 mm diameter. ≤ 6 mm thickness.
Beam splitter type	Cube
Beam splitter options	50:50, 70:30; 90:10, dichroic
Optical distance between entrance port and sensor	260 mm
External output ports	Two C-Mount ports on each arm. Each port with 4-40 screw holes for 30 mm cage optics.
External Connectors	1 x BNC Trigger in 1 x BNC Trigger out 1 x 5 VDC Power in
Tripod mounting	4 x ¼-20 and 4 x M6 threaded holes on bottom near center
Construction	CNC 6061 Aluminum with Stainless Steel hardware
Surface finish	Hard black anodization with laser etching
Dimensions (W x D x H) – not including feet	198 mm x 198 mm x 70 mm
Foot adjustment	20-40 mm vertically
Weight	3 kg

# 5. Drawings

## System Layout

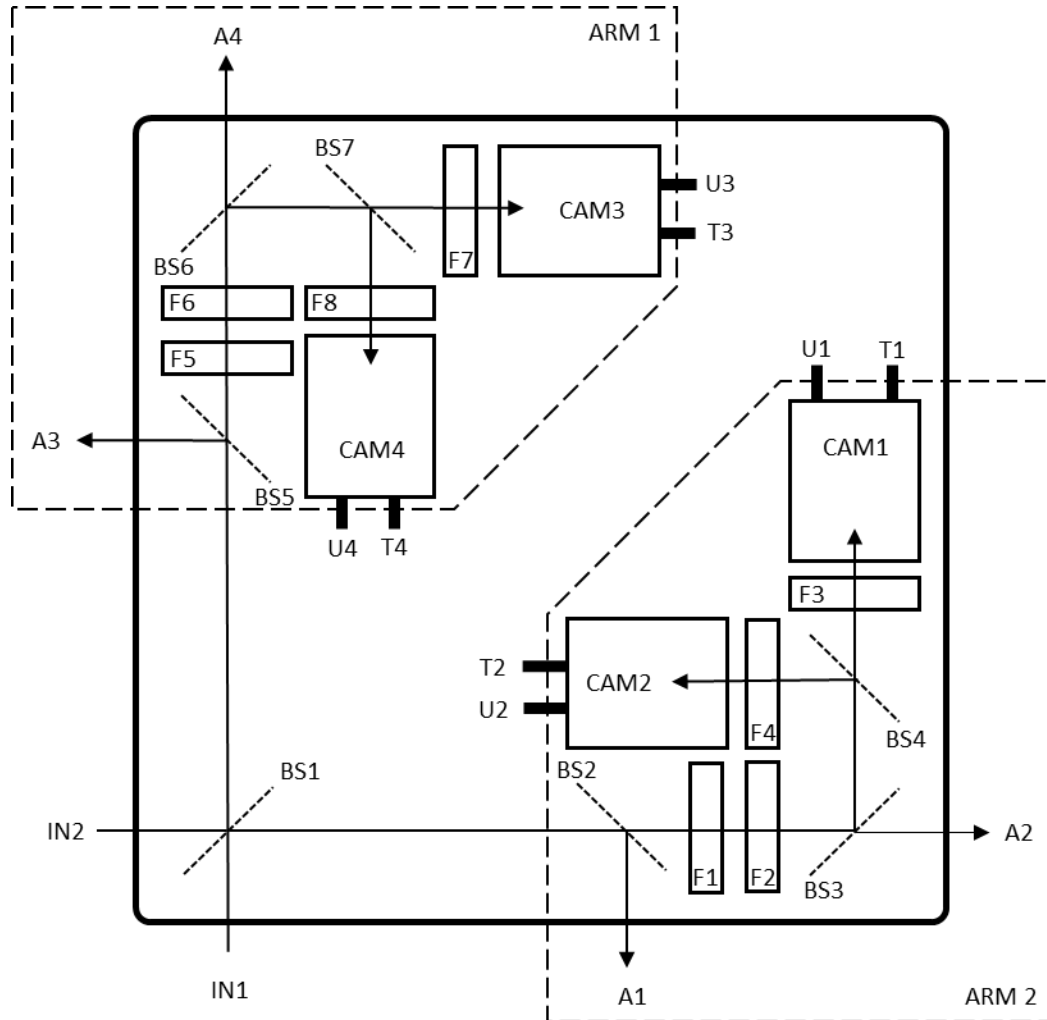

Drawing shows a schematic of the internals of the MSMC-1-4. The drawing illustrates the layout of the cameras (CAM\*) with respect to the beam splitters (BS\*) and filters (F\*). Each camera has a USB3 data connection (U\*) and a trigger input/output (T\*). One camera can act as a master and trigger the others. Alternatively, the four cameras can be triggered with an external signal through a BNC connection on the side of the unit. The trigger signal is available as a signal output on a BNC connector on the side of the unit.

## Front

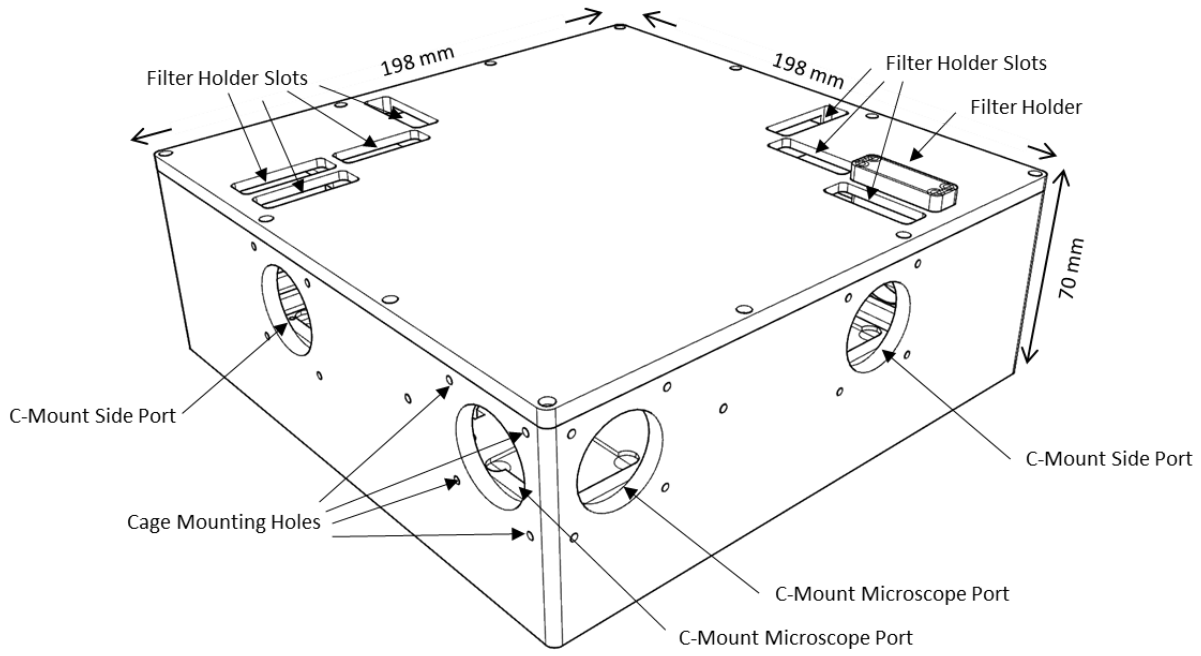

## Back

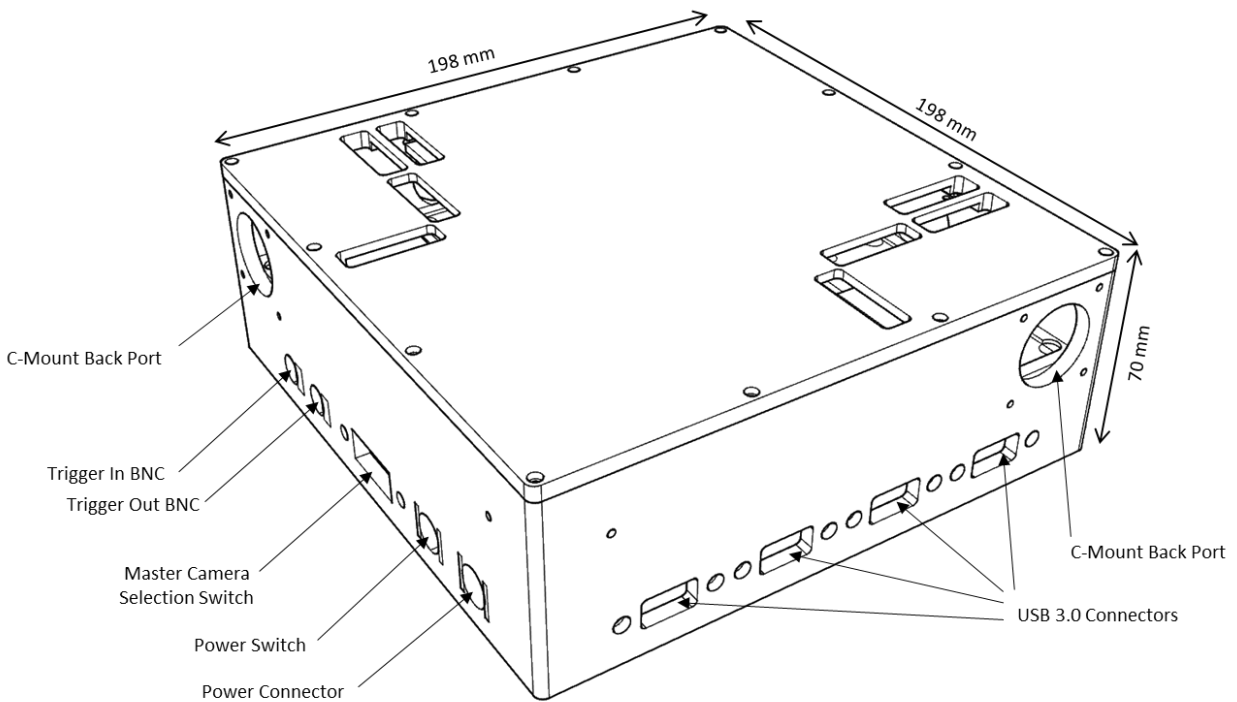

## 6. SDKs

Included with the MSMC-1-4 is an industrial-grade SDK for camera control and image capture. The SDK is compatible with a variety of Windows, Linux and MacOS operating systems. It includes drivers, libraries, documentation, and samples. Environments such as Python and OpenCV are also supported.

Operating System	Development Environments	SDK Includes
Windows 11 (64bit) Windows 10 (32bit / 64bit) Windows 8.1 (32bit / 64bit)	Visual Studio 2005 Visual Studio 2008 Visual Studio 2010 Visual Studio 2012 Visual Studio 2013 Visual Studio 2015 Visual Studio 2017 Visual Studio 2019 Visual Studio 2022 MinGW (Minimalist GNU for Windows) embarcadero Free C++ Compiler Python 3.7.x Python 3.8.x Python 3.9.x Python 3.10.x	Windows driver Windows SDK StApi (Visual C++, .net Framework 2.0, C) StGenTL module Viewing Software (StViewer) Sample Programs (Visual C++, Visual C#, Visual Basic, C) DirectShow Filter Documentation
MacOS 13 Ventura MacOS 12 Monterey MacOS 11 BigSur	Python 3.7.x Python 3.8.x Python 3.9.x Python 3.10.x	StApi (C++) StGenTL module Viewing Software (StViewer) Sample Programs Documentation
Linux 64bit x64 Linux 64bit ARM Linux 32bit ARM	Python 3.7.x Python 3.8.x Python 3.9.x Python 3.10.x	StApi (C++, C) StGenTL module Viewing Software (StViewer) Sample Programs (C++, C) Documentation

## 7. Windows Software

2ndLook software is included with each system purchase. 2ndLook is an image acquisition software package offering a complete solution to the customers looking for a user-friendly way to connect and acquire images without any development experience



necessary. 2ndLook provides real-time synchronized video recording from multiple cameras (GeniCam-compliant USB3 Vision, GigE Vision, and DirectShow cameras ) to popular file formats (AVI, TIFF, PNG, JPEG) (Fig. 10.1). It has an easy to use interface with interactive help and user guides.



Figure 10.1. Real-time display of raw multispectral images.