



The MSC2 VIS8 is ultra-compact, ultra-light multispectral camera with a high performance 4MP CMOS sensor modified with Spectral Devices proprietary Anti-X-Talk™ multispectral filter array technology.

## FEATURES

- Captures co-registered spectral images simultaneously
- 8 bands – 474, 495, 526, 546, 578, 602, 621, 640 nm
- Anti-X-Talk™ Technology - enhances contrast and spectral performance
- Sustained frame rates @ 89 FPS
- 4MP Global Shutter CMOS sensor
- USB3 Vision & GenICam Compliant
- Ultra-compact (28 x 28 x 47 mm)
- Ultra-light (< 55g)
- Accommodates c-mount lenses

## SENSOR

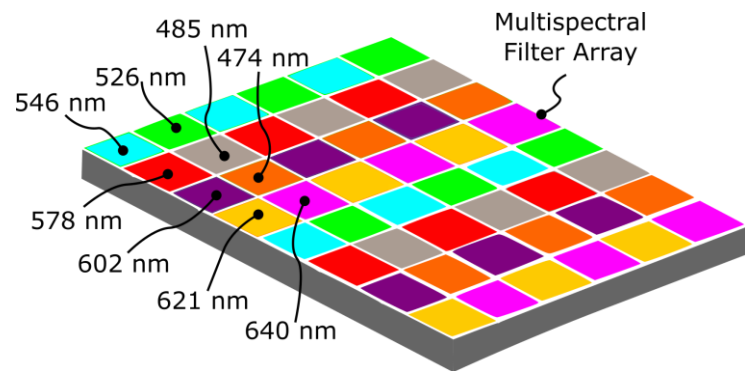

## SPECTRAL RESPONSE

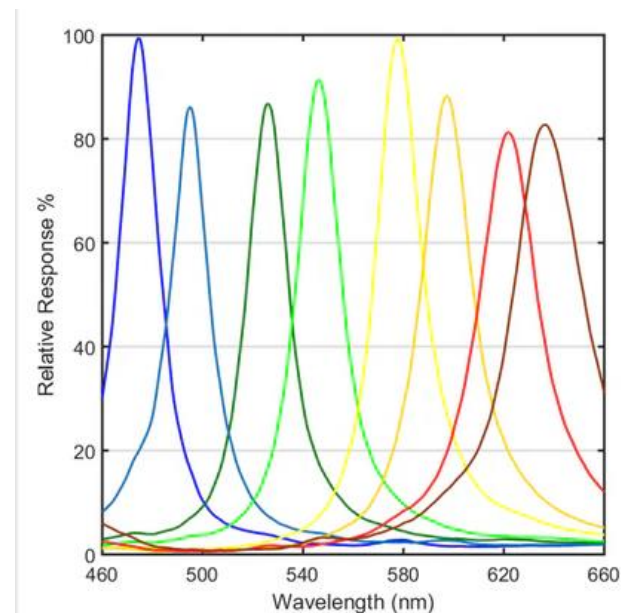

## QUANTUM EFFICIENCY

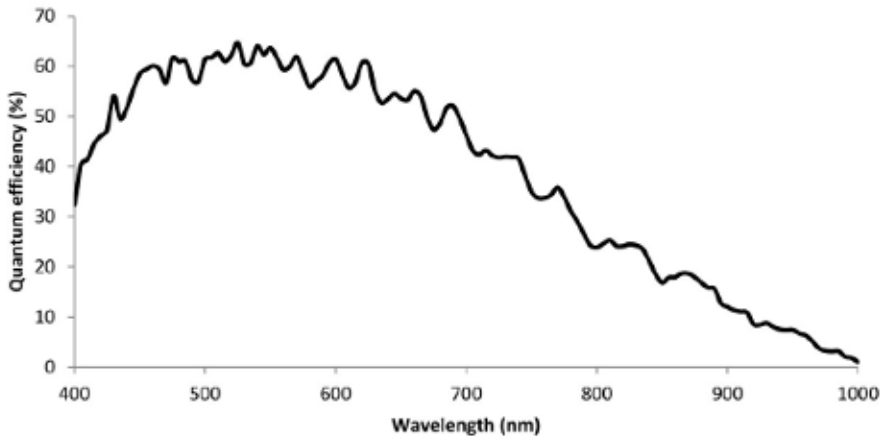

## DIMENSIONS

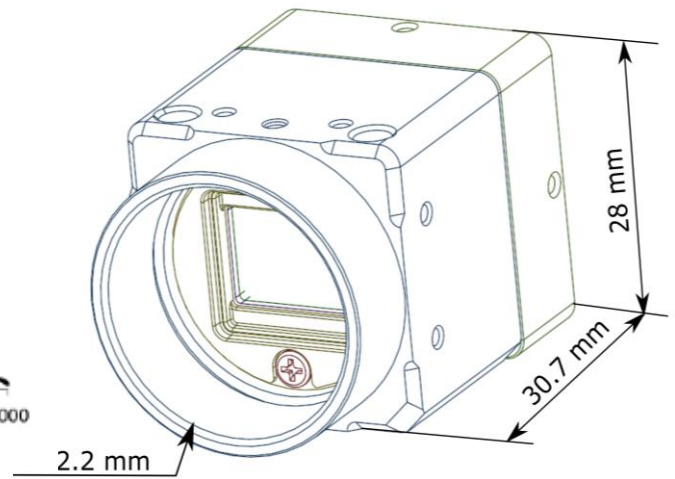

## TECHNICAL SPECIFICATIONS

Feature	Description
# of bands	8
Band Locations	474, 495, 526, 546, 578, 602, 621, 640 nm
Spectral Bandwidth	20-35 nm
Pixels/band	256x256
Sensor Type	CMOS
Sensor Model	AMS CMV4000
Sensor Format	1-inch
Effective pixel size	5.5 x 5.5 $\mu\text{m}$
Shutter Type	Global
Frame Rate	8bits @ 89 fps 10bits @ 45 fps 12bits @ 37 fps

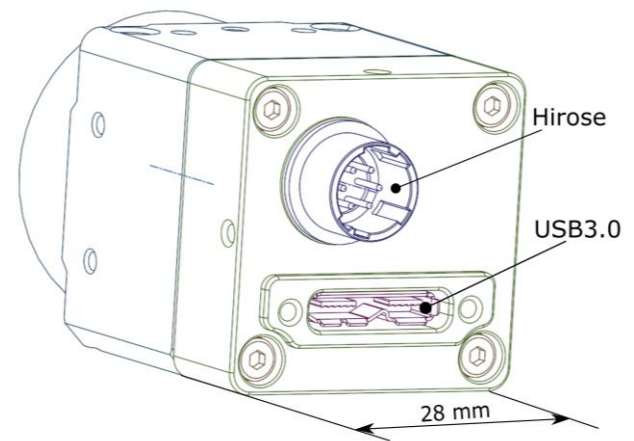

Feature	Description
Noise Level (Gain 0 dB)	8bits output: <3 digits 10bits output: <12 digits 12bits output: <48 digits
Exposure Time	22 $\mu\text{s}$ to 16.77 s
Lens Compatibility	c-mount
Connectors	USB 3.0, Hirose
System Sync	External trigger (Hardware, Software), Free run