

SPECIFICATION

Ultra-Wide Band Multisensor Drone Camera system

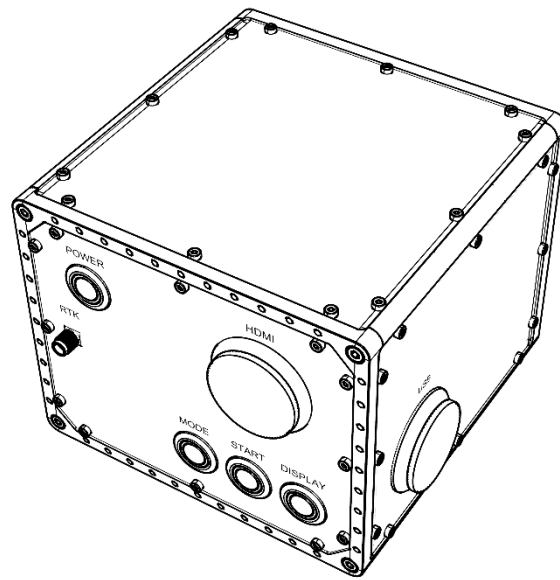

MSDC-2-4-UWB

Version 01

April 20, 2024

Specifications subject to change

Table of Contents

Background information.....	3
Trademarks.....	3
Sales and Support.....	3
1. Description	4
2. Key Features	5
3. Specifications	6
4. Drawings.....	7
5. Package Contents	8
6. Software	8
Features.....	9
7. Image Post-processing	11

Background information

Trademarks

Spectral Devices Inc., MSDC, MSC2, MSDC-2-4, MSDC-2-4-UWB

Sales and Support

Contact Type	Contact Information
Email	sales@spectraldevices.com support@spectraldevices.com
Knowledge Base and Downloads	www.spectraldevices.com
Main Office	Spectral Devices Inc. 800 Collip Circle, Suite 129-130 London, Ontario, Canada N6G 4X8 +1-888-988-2077

1. Description

The multisensor drone camera system (MSDC-2-4) is a turnkey multispectral imaging solution for easy integration with many drones enabling capture of geotagged aerial images for further analysis in data mapping software.

Each MSDC-2-4 (Fig.1a) includes up to 4 cameras with C-mount lenses optimized for customer specified field of view and ground resolution. All camera optical axis are aligned during the manufacturing process to ensure seamless image co-registration between cameras.

A built-in vision computer provides a high degree of control over the cameras, ensuring synchronized camera operation and image recording. System configuration is performed using simple text-based configuration files. Depending on the setup of the system, these settings can be modified by editing the files directly on a USB drive or an SD card before initiating the flight.

The MSDC-2-4 is equipped with a built-in GPS operating at 10 Hz and RTK base station enabling centimeter-level positional accuracy (Fig.1b). The system also incorporates a solar sensor (Fig.1b) with 19-channel spectrometer in UV-SWIR range, IMU providing 3-DOF sensor orientation and directional sensor for sun angle estimation.

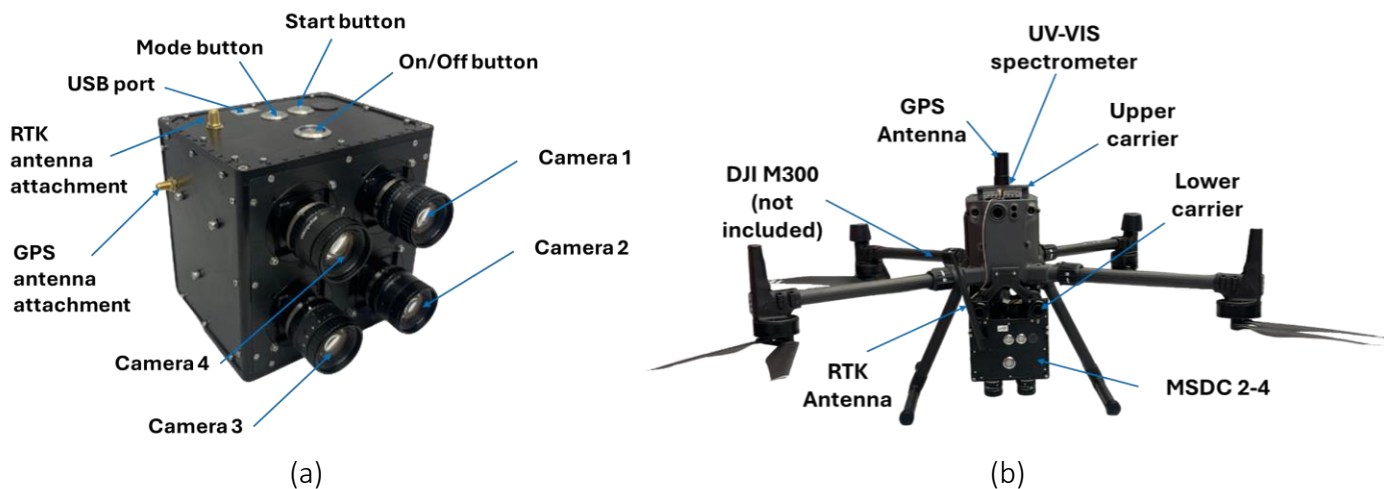

Figure 1. (a) MSDC 2-4 system. Note: position of switches and access ports is dependent on internal camera configuration. (b) MSDC-2-4 system mounted on a DJI M300 drone.

Operation of the system is simplified to only three pushbuttons – power, start, mode. The power button turns the system on or off. Start button starts and stops image acquisition and initiates computer shutdown. The Mode button cycles the system between image acquisition and computer shutdown mode.

Acquired images are saved on the USB drive or SD card (dependent on system configuration) and can be inspected using a PC and image post-processing software called msInspector. The software enables flight image and data (gps, solar) review and subsequent tagging with geo-location and radiometric correction data.

Although the system is designed to work with the DJI M300 RTK drone, integration on other drone models is possible if sufficient payload capacity (2 kg) and power (9-36V) is available.

The MSDC-2-4-UWB drone camera system is designed for exploratory work requiring a wide range of wavelengths. The system has a camera with 3 visible wavelengths (445, 532, 645 nm) for color imaging, near-infrared camera (800 nm), shortwave infrared camera (1500 nm) and thermal camera for operation between 8-12 μm .

2. Key Features

- Diverse Camera Array
 - 5 MP narrow band NIR camera
 - Thermal camera
 - 1.3 MP SWIR
 - 5 MP narrow band color camera
- Seamless Integration and User-Friendly Design
 - Compatible with a wide range of drones capable of carrying a payload of 1.7 kg and supplying 9 - 36V DC power
 - Designed with user-friendliness in mind, ensuring ease of use even for those new to drone technology
- Built-in Vision Computer
 - Real-time HDMI output of multispectral images
 - Sustained frame rates of up to 1 FPS with simultaneous recording to USB drive or SD card
 - Over 4 h of sustained frame recording at 1 FPS with a 512 GB USB drive (12-bit mode)
- Built-in GPS
 - High performance GPS with 10 Hz update rate
 - Includes RTK base station for centimeter-level accuracy and 20 km range
- Solar sensor
 - 19 channel spectrometer
 - Built-in IMU for orientation
 - Built-in directional sensor
- Enables comprehensive analysis of multispectral data
 - Agricultural and environmental monitoring: NDVI, GNDVI, EVI, MSAVI, NDWI, MSI, NDMI, NBI
 - Thermal monitoring
 - Structural and infrastructure inspections
 - Archeological exploration
- Advanced Post-Processing Software
 - The system comes equipped with sophisticated image post-processing software
 - Provides the radiometric correction data and adds it to the image metadata
 - Geotagging for precise location mapping
 - Support provided for orthomosaic map generation

3. Specifications

Table 1. List of cameras in the MSDC-2-4-UWB system

CAMERA	TYPE	#BANDS	RESOLUTION/BAND	BANDS	BANDWIDTH (FWHM)
NIR	Area scan	1	2448 x 2048	800 nm	50 nm
SWIR	Area scan	1	1280 x 1024	1500 nm	50 nm
Thermal	Area scan	1	1280 x 1024	Thermal	8-12 μ m
COLOR	Area scan	3	2448 x 2048	445 nm, 532 nm, 645 nm	35 nm, 25 nm, 60 nm

Table 2. Specifications of the MSDC-2-4-UWB system

Lens compatibility	All Spectral Devices C-mount lenses
Thermal control	Passive conduction of camera heat to enclosure
Water-resistant	Yes (IP54)
Dust-resistant	Yes (IP54)
Connector access	USB, SD card, HDMI, power cable, two SMA connectors for GPS antenna and RTK antennas
External construction	Aluminum with Stainless-steel hardware
Surface finish	Black anodization with laser etching
Dimensions	136 mm x 136 mm x 110 mm (150 mm with lenses)
Weight	1.70 kg with lenses. 1.38 kg without lenses
Power input	9 - 36 V DC directly from the drone
Image Geolocation	GPS/GNSS @ 10Hz
Frame rate	up to 1 FPS with simultaneous recording to USB drive or SD card

4. Drawings

RENDERED TOP VIEW

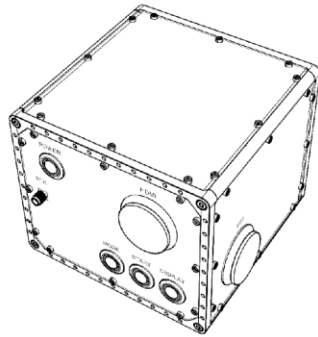

RENDERED BOTTOM VIEW

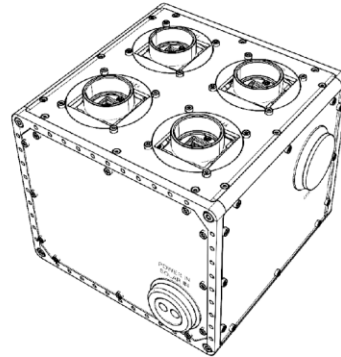

TOP VIEW

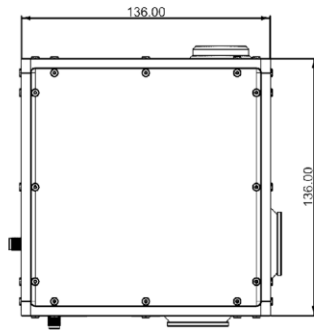

BOTTOM VIEW

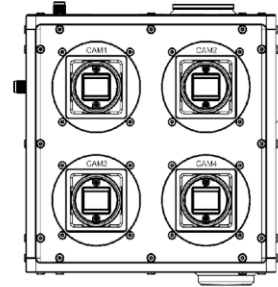

FRONT VIEW

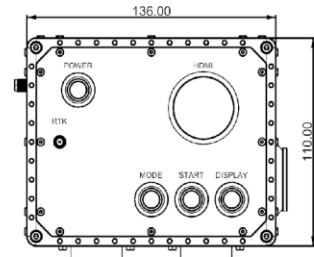

BACK VIEW

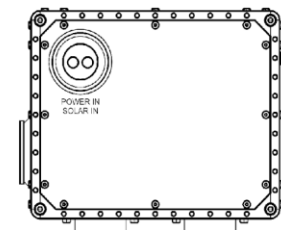

LEFT VIEW

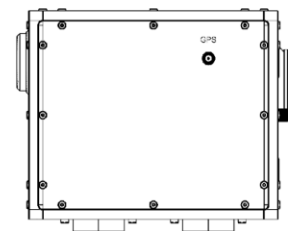

RIGHT VIEW

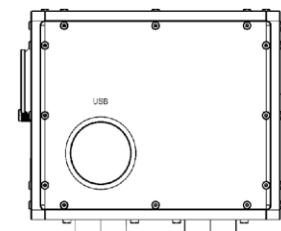

Figure 2. MSDC-2-4 system drawings.

5. Package Contents

Package contents are listed in Table 3 and shown in Fig.3a. All items are supplied in a waterproof equipment case (Fig.3b).

Table 3. MSDC-2-4-UWB package contents

MSDC-2-4-UWB	As shown in Fig.1a.
Lower carrier	Attachment for MSDC-2-4 to the drone
Upper carrier	Attachment for the solar sensor, GPS antenna to the drone and accommodates power regulator board for power connection between the payload and the drone
Two GPS Antennas	Attaches to MSDC-2-4 and RTK base station
RTK antenna	Attaches to RTK base station
RTK base station	Improves GPS accuracy
Two 256 GB SD cards	Used for image saving during flights
SD card adapter	For connection to most PC SD card slots
Solar sensor	Attaches to the upper carrier and connects to the MSDC-2-4 via USB3.0
Power cable	Connects MSDC-2-4 to the power regulator board in the upper carrier
Hex keys	Necessary keys for MSDC-2-4 attachment to the drone
Protective lens covers	Protects lenses when not in use

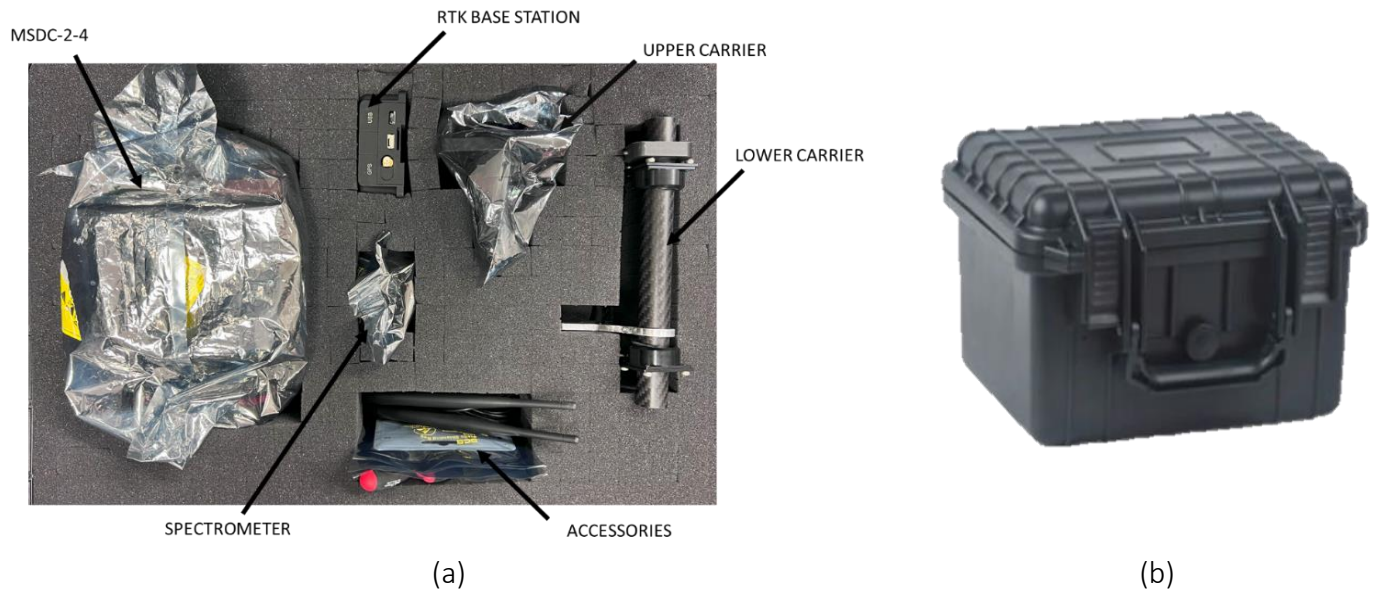

Figure 3. (a) MSDC-2-4 system package and its contents, (b) waterproof equipment case.

6. Software

With every MSDC-2-4, Spectral Devices provides mslInspector, a Windows-based application featuring a graphical user interface (GUI). The software makes inspection and geotagging of images collected with the MSDC series multispectral drone cameras from Spectral Devices Inc quick and easy.

The software onboard the MSDC-2-4 performs real-time preprocessing of images from each camera. For example, multispectral images are demosaiced and saved in TIFF format onto the removable USB drive or SD

card. While single band cameras, such as the SWIR and Red Edge are saved directly to the drive. Images are saved into a hierarchical folder system ensuring no data is overwritten between flights.

msInspector uses configuration, calibration, and correction files specific to each MSDC-2-4 camera. The calibration and correction files are supplied by Spectral Devices. msInspector provides a series of batch operations allowing the user to load images, solar sensor data, and GPS data. At each step, data can be visualized. Lastly, the GPS and solar data can be written into the image metadata.

Features

1. Simple, easy to use tabbed GUI.
2. Data visualization (images, GPS and solar sensor data)
3. Geotags large numbers of images in a single operation.
4. Tags solar sensor data to the images for radiometric calibration.
5. Exports geotagged images in multiple formats to the desired folder.
6. Provides tags required by 3rd party mapping software.

In the msInspector Camera tab the user can review all the collected images and apply non-uniformity corrections to the images (Fig.4).

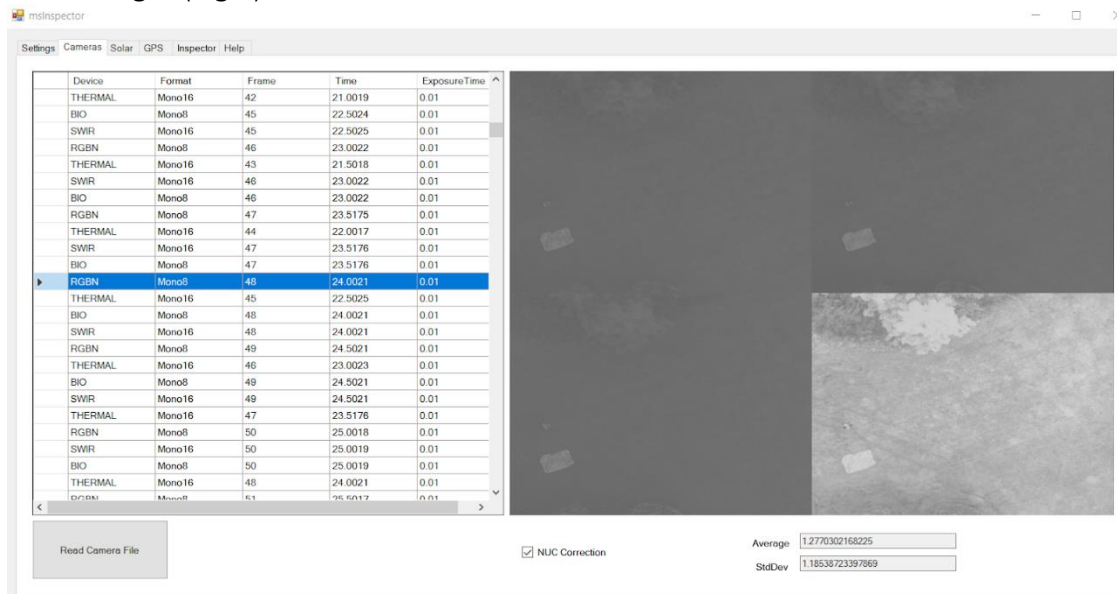

Figure 4. Camera tab in the msInspector.

Solar tab (Fig.5) in the msInspector allows user to review data collected by the solar sensor during the flight. Data includes the spectrometer reading across the VIS-NIR spectrum, sensor orientation (yaw, pitch, roll), and solar direction relative to the sensor.

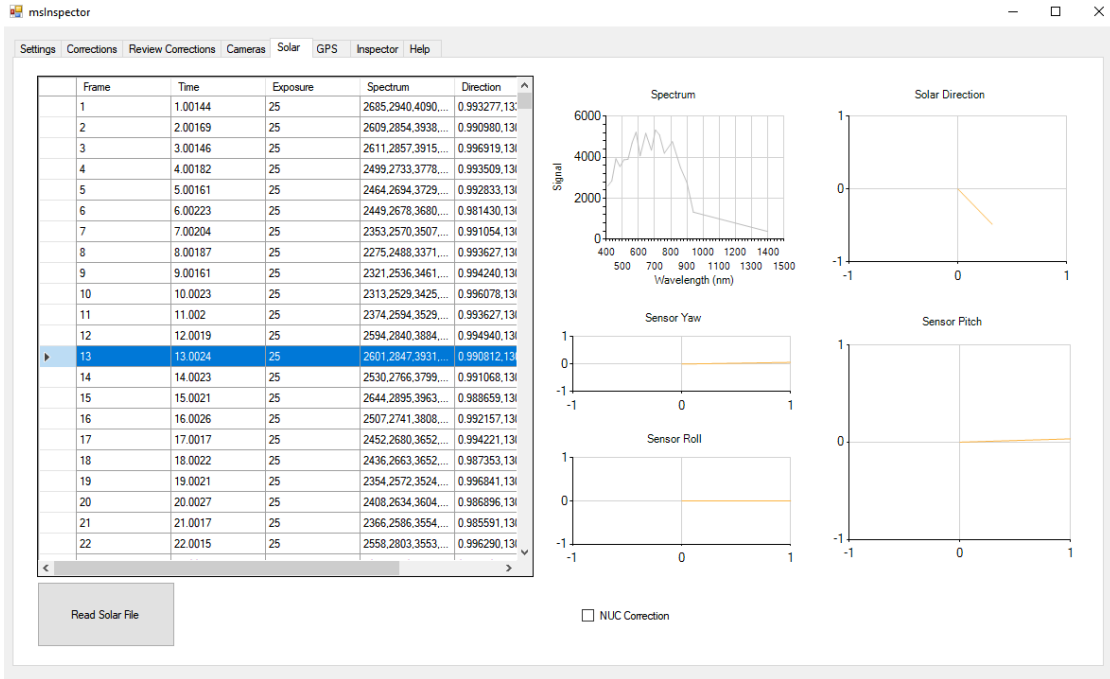

Figure 5. Solar tab in the msInspector.

GPS tab (Fig.6) in the msInspector allows the user to review GPS data collected by the GPS sensor (longitude, latitude, and altitude) during the flight. A map is displayed showing the location of the flight along with the flight path.

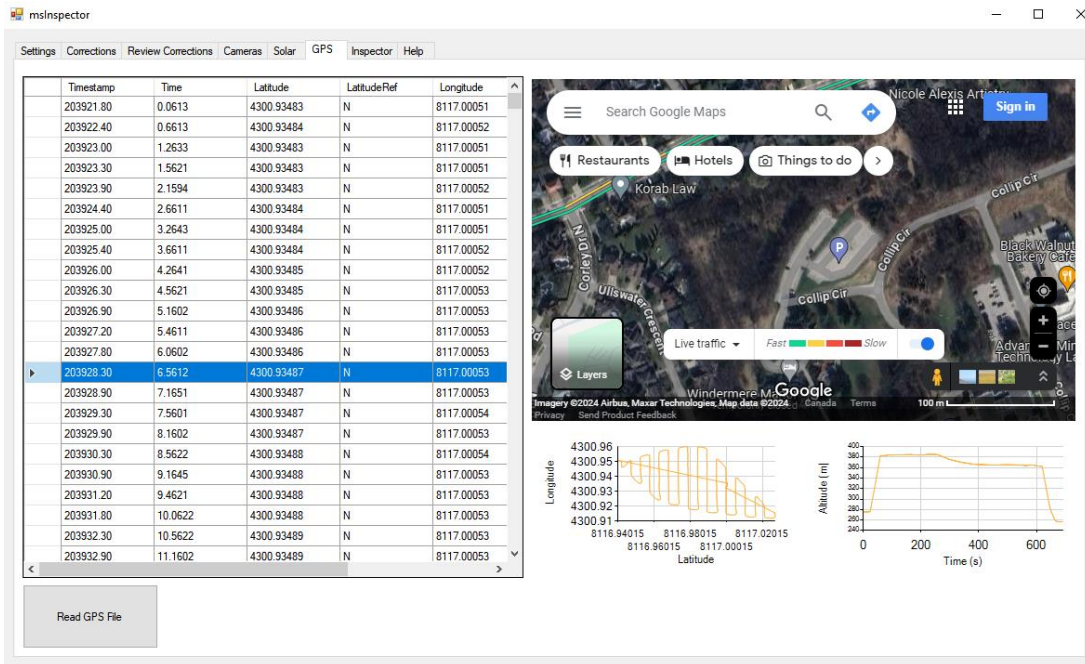

Figure 6. GPS tab in the msInspector.

The Inspector tab (Fig.7) in the msInspector allows the user to review all the data together. This data is used for image metadata generation. From this tab, geotagged images are exported with all the necessary metadata for image post-processing using software such as WebODM or Pix4DFields.

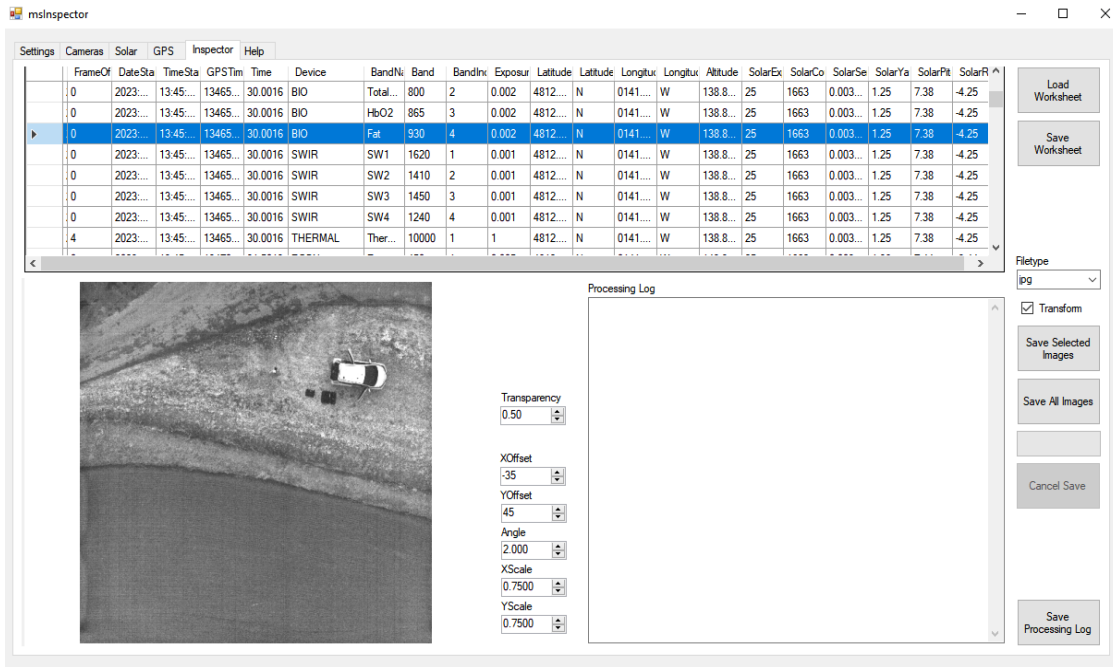

Figure 7. GPS tab in the mslInspector.

7. Image Post-processing

Images exported from the mslInspector are ready for 3D model reconstruction and orthomosaic map generation using open-source software WebODM by Open Drone Maps or subscription software Pix4D.

Spectral Devices Inc. provides tutorials and guides for image post-processing.