

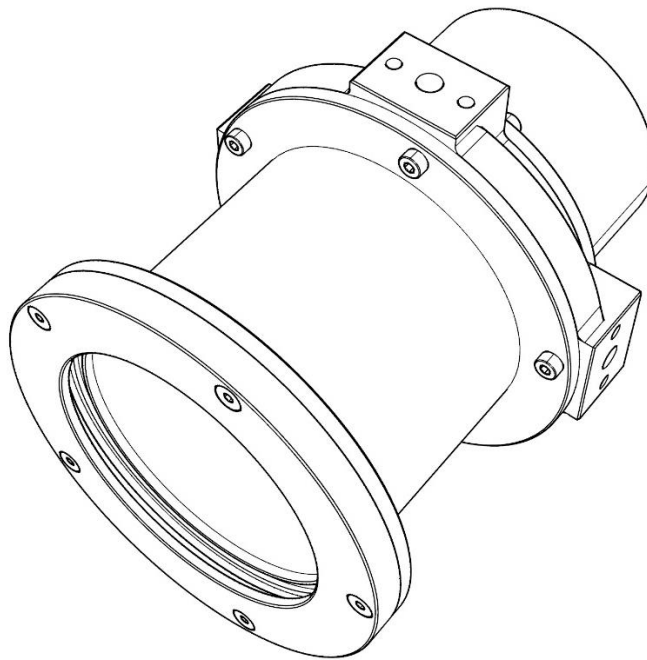

Product Sheet

Multispectral Camera Enclosure

MSCE-MSC2-1-B



MSCE-MSC2-1-B
Specifications subject to change
Revised March 12, 2023

Table of Contents

1. Description.....	3
2. Key Features	3
3. Applications	3
4. Specifications	4
5. Drawing.....	5

1. Description

The MSCE-MS2-1-B is a waterproof and dustproof camera enclosure for Spectral Devices MSC2 series of multispectral cameras (not included). The enclosure provides protection of MSC2 cameras from harsh environments where moisture and dust are present. The enclosure is capable of withstanding submersion in water up to a depth of 1 m. The front window is uncoated borosilicate glass which is spectrally compatible with all MSC2 series camera types. The large diameter enclosure accommodates even the largest C-mount lenses available from Spectral Devices (not included). Camera position inside the enclosure is adjustable from front to back to accommodate lenses of different sizes. The front and back enclosure tubes are easily removed with the included 3 mm hex driver. Removal of the front enclosure tube provides access to the focus and iris adjustments on the lens. Removal of the back enclosure tube provides access to the cable connections to the MSC2. The camera cables enter the enclosure through a removable waterproof seal. Users requiring only a USB cable connection to the MSC2 can use the included one-hole seal. Users requiring both a USB cable connection and a GPIO trigger cable connection can use the included two-hole seal. The enclosure is CNC machined from 6061 aluminum with black anodization.

2. Key Features

- Compact design
- Waterproof and dustproof (IP67)
- Easy access to camera from front and back
- CNC machined aluminum components
- Black anodized finish
- Stainless steel hardware
- Large front window (Ø91 mm)
- Three versatile mounting points
- T-slot compatible mounting screw holes
- Cable entry through waterproof rubber seal

3. Applications

- Research and development
- Industrial machine vision
- Tractor-mounted imaging applications
- Greenhouse monitoring
- CCTV-like monitoring
- Underwater imaging

4. Specifications

Camera compatibility	All Spectral Devices MSC2 series cameras
Lens compatibility	All Spectral Devices C-mount lenses Standard: all focal lengths Low Distortion: all focal lengths Ruggedized: all focal lengths
Usable window aperture	91 mm diameter
Window material	6.5 mm thick borosilicate glass (uncoated)
Thermal control	Passive conduction of camera heat to enclosure
Waterproof	Yes (IP67)
Dustproof	Yes (IP67)
Camera access	Front or back via 5 x M4 screws. A 3mm hex driver is included.
Cable access	4 x M3 screws. A 2.5 mm hex driver is included.
Number of mounting points	3 (left, right, bottom)
Number of mounting holes	3 at each mounting point (1 x M8x14mm, 2 x M5x14mm)
T-slot compatible	Yes (20 mm and 40 mm)
External construction	6061 aluminum, borosilicate glass, and 316 stainless steel hardware
Surface finish	Black anodization
Cable entry	One or two Ø5-6mm cables through removable seal Connector-less design
Dimensions	Overall length: 175 mm Front flange: Ø130 mm Mounting points: 62.5 mm from optical axis of camera
Weight	900 g without camera and lens

5. Drawing

MSCE-MS2-1-B: 6061 Aluminium. Black Hard Anodized Finish
(all dimensions in mm; tolerance +/-0.05mm)

RENDERED TOP VIEW

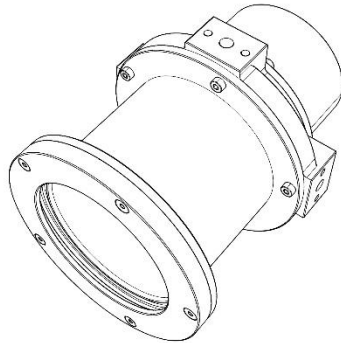

RENDERED BOTTOM VIEW

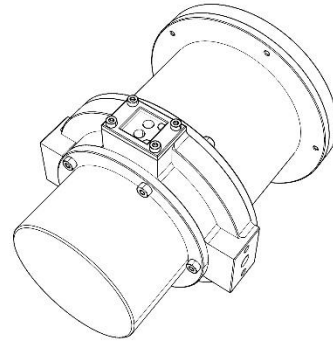

TOP VIEW

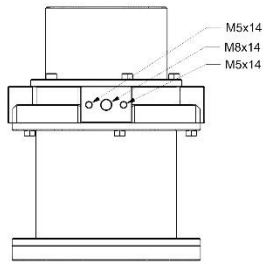

BOTTOM VIEW

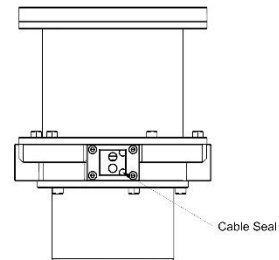

FRONT VIEW

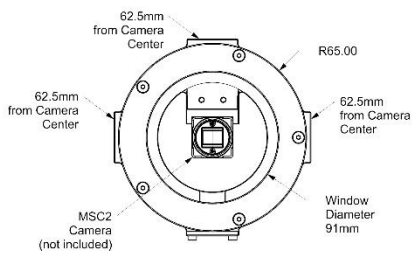

BACK VIEW

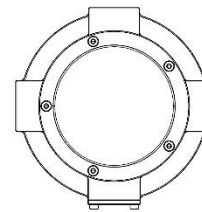

LEFT VIEW

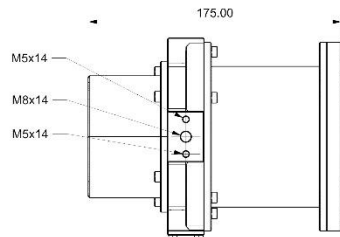

RIGHT VIEW

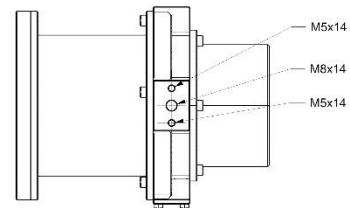

Copyright (C) 2023 Spectral Devices Inc.